

CFD Series

Reach In Refrigerators / Freezers

The CFD Series of commercial reach in refrigerators and freezers brings high performance and quality to your kitchen. Designed to be functional and efficient, the CFD Series provides the best value in commercial refrigeration.



- High quality stainless steel interior & exterior
- ETL Safety & Sanitation Approved
- Digital temperature controls w/LCD display
- Outstanding temperature preservation & reduced energy consumption

REFRIGERATION
AVANTCO



With its durable, 430 series stainless steel exterior and 304 series stainless steel interior, the Avantco CFD double door reach in refrigerator is strong enough to stand up to the daily demands of your busy restaurant kitchen.

The Avantco CFD 2 door reach in refrigerator features self closing doors and four casters, two of which are locking, which make it easy to move the reach in refrigerator for cleaning and servicing. Digital controls and an LCD readout make it easy to adjust the interior temperature.

Six plastic coated wire shelves are included. For maximum versatility, the shelves slide easily in and out of the reach in on heavy duty slide rails. You can even remove the shelves and slide in full size food pans!

The Avantco CFD reach in refrigerator's bottom mounted, 1/2 hp compressor uses R134a refrigerant and is easily accessible for cleaning and maintenance. Foamed in place polyurethane cell insulation helps maintain interior temperatures. The reach in refrigerator has a temperature range of 32 to 50 degrees Fahrenheit.

The Avantco CFD double door reach in refrigerator has a 120V, 8.4 amp, 60 Hz electrical rating, and is ETL Sanitation Listed and NSF Compliant.

Features

- 304 series stainless steel interior
- 430 series stainless steel exterior
- Self closing doors
- Recessed door handles
- 6 plastic coated steel shelves included
- Heavy duty shelf rails accept full size food pans
- Digital temperature controls with LCD Display
- Automatic defrosting
- 4 casters (two locking)
- Door locks
- Foamed in place polyurethane insulation
- ETL Sanitation Listed

Technical Data

Dimensions

Exterior Dimensions (W x D x H)	54" x 32.25" x 82.5"
Interior Dimensions (W x D x H)	49.5" x 27" x 60.25"
Net Volume (cu. ft.)	46.5 cu. ft.
Net Weight	446.6 lbs.
Packaging Dimensions (W x D x H)	56.25" x 34.5" x 83.5"

Cooling

Temperature Range	32° - 50° F
Refrigerant	R134a
Maximum Ambient Temperature Rating	100.4° F
Defrosting	Automatic
Temperature Display	Yes
Temperature Controller	Digital
Horsepower	1/2

Construction

Exterior Material	430 series stainless steel
Interior Material	304 series stainless steel
Insulation Material	Foamed in place polyurethane
Shelf Material	Plastic coated steel
Shelf Load Capacity	120 lbs.

Electrical

Voltage	120
Amps	8.4
Hz	60
Phase	1
Electrical Cord Length	96"

Plan View

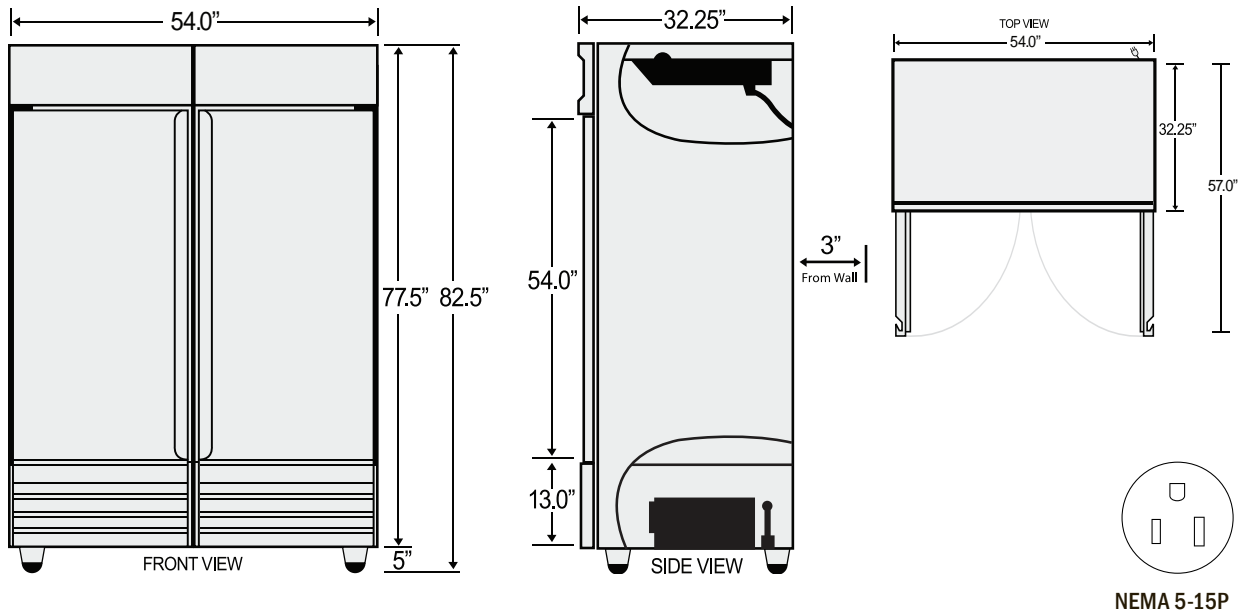



1 year
WARRANTY

Parts & Labor



5 year
WARRANTY

Compressor

All Avantco Refrigerators and Freezers are backed by a 1 year parts and labor warranty, with a 5 year warranty on the compressor. For warranty inquiries or service, first locate the serial number plate on the front of the unit, or inside the door jamb. Next, call 1-800-678-5517. Be sure to have the serial and model numbers available when contacting service technicians.